

## DN6.46x - 48 channel 16 bit digitizerNETBOX up to 3 MS/s

- 16, 24, 32, 40 or 48 channels with 200 kS/s up to 3 MS/s
- Software selectable single-ended or differential inputs
- Simultaneously sampling on all channels
- Separate ADC and amplifier per channel
- complete on-board calibration
- 8 input ranges:  $\pm 50$  mV up to  $\pm 10$  V
- 512 MSample/1 GSample standard acquisition memory
- Programmable input offset of  $\pm 5$  V
- Window, pulse width, re-arm, spike, OR/AND trigger
- Features: Streaming, ABA mode, Multiple Recording, Gated Sampling



- Ethernet Remote Instrument
- LXI Core 2011 compatible
- GBit Ethernet Interface
- Sustained streaming mode up to 70 MB/s
- Direct Connection to PC/Laptop
- Connect anywhere in company LAN
- Embedded Webserver for Maintenance/Updates
- Embedded Server option for open Linux platform

Operating Systems	SBench 6 Professional Included	Drivers
<ul style="list-style-type: none"> <li>• Windows XP, Vista, 7, 8, 10</li> <li>• Linux Kernel 2.6, 3.x, 4.x</li> <li>• Windows/Linux 32 and 64 bit</li> </ul>	<ul style="list-style-type: none"> <li>• Acquisition, Generation and Display of analog and digital data</li> <li>• Calculation, Documentation and Import, Export</li> </ul>	<ul style="list-style-type: none"> <li>• LabVIEW, MATLAB, LabWindows/CVI</li> <li>• C/C++, GNU C++, VB.NET, C#, J#, Borland Delphi, Java, Python, IVI</li> </ul>

Model	Single-Ended		Differential		Total Memory
	Channels	Speed	Channels	Speed	
DN6.461-16	16	200 kS/s	16	200 kS/s	1.0 GSample
DN6.461-24	24	200 kS/s	24	200 kS/s	1.5 GSample
DN6.461-32	32	200 kS/s			2.0 GSample
DN6.461-40	40	200 kS/s			2.5 GSample
DN6.461-48	48	200 kS/s			3.0 GSample
DN6.464-16	16	1 MS/s	16	200 kS/s	1.0 GSample
DN6.464-24	24	1 MS/s	24	200 kS/s	1.5 GSample
DN6.464-32	32	1 MS/s			2.0 GSample
DN6.464-40	40	1 MS/s			2.5 GSample
DN6.464-48	48	1 MS/s			3.0 GSample
DN6.465-16	16	3 MS/s	16	200 kS/s	1.0 GSample
DN6.465-24	24	3 MS/s	24	200 kS/s	1.5 GSample
DN6.465-32	32	3 MS/s			2.0 GSample
DN6.465-40	40	3 MS/s			2.5 GSample
DN6.465-48	48	3 MS/s			3.0 GSample

### General Information

The digitizerNETBOX DN6.46x series allows recording of up to 48 channels with sampling rates of 3 MS/s with 16 bit resolution and sampling rates between 200 kS/s and 3 MS/s. All 16 and 24 channel models allow to switch each channel independently between single-ended and true differential input. These Ethernet Remote instruments offer outstanding A/D features both in resolution and signal quality. The 16 bit vertical resolution have four times the accuracy compared to 14 bit products and sixteen times the accuracy if compared with a 12 bit product. The digitizerNETBOX can be installed anywhere in the company LAN and can be remotely controlled from a host PC.

## Software Support

### Windows Support

The digitizerNETBOX/generatorNETBOX can be accessed from Windows XP, as well as Vista, Windows 7, Windows 8, Windows 10 (each 32 bit and 64 bit). Programming examples for Visual C++, Borland C++ Builder, LabWindows/CVI, Borland Delphi, Visual Basic, VB.NET, C#, J#, Python, Java and IVI are included.

### Linux Support



The digitizerNETBOX/generatorNETBOX can be accessed from any Linux system. The Linux support includes SMP systems, 32 bit and 64 bit systems, versatile programming examples for Gnu C++, Python as well as drivers for MATLAB for Linux. SBench 6, the powerful data acquisition and analysis software from Spectrum is also included as a Linux version.

### Discovery Protocol

Physical Location	
Bus No	0
Device No	0
Function No	0
Slot No	0
IP	192.168.169.14
VISA	TCP/IP[0]:192.168.169.14::inst0::INSTR

The Discovery function helps you to find and identify any Spectrum LXI instruments, like the digitizerNETBOX and generatorNETBOX, avail-

able to your computer on the network. The Discovery function will also locate any Spectrum card products that are managed by an installed Spectrum Remote Server somewhere on the network.

After running the discovery function the card information is cached and can be directly accessed by SBench 6. Furthermore the qualified VISA address is returned and can be used by any software to access the remote instrument.

### SBench 6 Professional

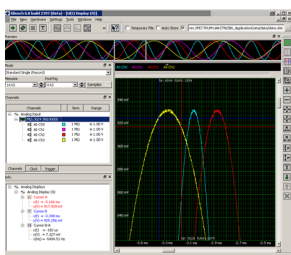

The digitizerNETBOX and generatorNETBOX can be used with Spectrum's powerful software SBench 6 – a Professional license for the software is already installed in the box. SBench 6 supports all of the standard features of the instrument. It has a variety of display windows as well as analysis, export and documentation

functions.

- Available for Windows XP, Vista, Windows 7, Windows 8, Windows 10 and Linux
- Easy to use interface with drag and drop, docking windows and context menus
- Display of analog and digital data, X-Y display, frequency domain and spread signals
- Designed to handle several GBytes of data
- Fast data preview functions

### IVI Driver

The IVI standards define an open driver architecture, a set of instrument classes, and shared software components. Together these provide critical elements needed for instrument interchangeability. IVI's defined Application Programming Interfaces (APIs) standardize common measurement functions reducing the time needed to learn a new IVI instrument.

The Spectrum products to be accessed with the IVI driver can be locally installed data acquisition cards, remotely installed data acquisition cards or remote LXI instruments like digitizerNETBOX/generatorNETBOX. To maximize the compatibility with existing IVI

based software installations, the Spectrum IVI driver supports IVI Scope, IVI Digitizer and IVI FGen class with IVI-C and IVI-COM interfaces.

### Third-party Software Products

Most popular third-party software products, such as LabVIEW, MATLAB or LabWindows/CVI are supported. All drivers come with examples and detailed documentation.

### Embedded Webserver



Instrument Welcome Page	
Instrument Model	DN2-465-08
Manufacturer	Spectrum GmbH
Serial Number	1234
Description	Spectrum GmbH, DN2-465-08, 1234, 3.32.13608
LXI Features	LXI Core 2011
LXI Version	LXI Device Specification 2011 rev. 1.4
Host Name	192.168.169.20
mDNS Host Name	DN2_465-08_sn1234.local
MAC Address	0C:C4:7A:B3:C2:A2
TCP/IP Address	192.168.169.20
Firmware Revision	40
Software Revision	3.32.13608
Instrument Address String [VISA]	TCP/IP::192.168.169.20::INSTR
LAN ID Indicator	Enable

The integrated webserver follows the LXI standard and gathers information on the product, set up of the Ethernet configuration and current status. It also allows the setting of a configuration password, access to documentation and updating of the complete instrument firmware, including the embedded remote server and the webserver.

### Hardware features and options

#### LXI Instrument



The digitizerNETBOX and generatorNETBOX are fully LXI instrument compatible to LXI Core 2011 following the LXI Device Specification 2011 rev. 1.4. The digitizerNETBOX/generatorNETBOX has been tested and approved by the LXI Consortium.

Located on the front panel is the main on/off switch, LEDs showing the LXI and Acquisition status and the LAN reset switch.

#### Front Panel



Standard BNC connectors are used for all analog input or output signals and all trigger and clock signals. No special adapter cables are needed and the connection is secure even when used in a moving environment.

Custom front panels are available on request even for small series, be it SMA, LEMO connectors or custom specific connectors.

#### Ethernet Connectivity



The GBit Ethernet connection can be used with COTS Ethernet cabling as well as special industrial grade Buceaneer Ethernet cables. The integration into a standard LAN allows to connect the digitizerNETBOX/generatorNETBOX either directly to a desktop PC or Laptop or it is possible

to place the instrument somewhere in the company LAN and access it from any desktop over the LAN.

## Input Amplifier

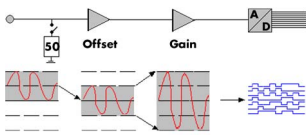

The analog inputs can be adapted to real world signals using a wide variety of settings that are individual for each channel. By using software commands the input termination can be changed between 50 Ohm and 1 MOhm, one can select a matching input range and the signal offset can be compensated for.

## Differential inputs

With a simple software command the inputs can individually be switched from single-ended (in relation to ground) to differential by combining each two single-ended inputs to one differential input. When the inputs are used in differential mode the A/D converter measures the difference between two lines with relation to system ground.

## Automatic on-board calibration

All of the channels are calibrated in factory before the board is shipped. To compensate for different variations like PC power supply, temperature and aging, the software driver provides routines for an automatic onboard offset and gain calibration of all input ranges. All the cards contain a high precision on-board calibration reference.

## Ring buffer mode

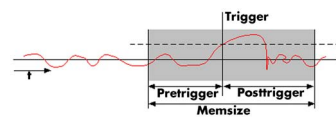

The ring buffer mode is the standard mode of all oscilloscope instruments. Digitized data is continuously written into a ring memory until a

trigger event is detected. After the trigger, post-trigger samples are recorded and pre-trigger samples can also be stored. The number of pre-trigger samples available simply equals the total ring memory size minus the number of post trigger samples.

## FIFO mode

The FIFO mode is designed for continuous data transfer between remote instrument and PC memory or hard disk. The control of the data stream is done automatically by the driver on interrupt request. The complete installed on-board memory is used for buffer data, making the continuous streaming extremely reliable.

## Channel trigger

The data acquisition instruments offer a wide variety of trigger modes. Besides the standard signal checking for level and edge as known from oscilloscopes it's also possible to define a window trigger. All trigger modes can be combined with the pulsewidth trigger. This makes it possible to trigger on signal errors like too long or too short pulses. In addition to this a re-arming mode (for accurate trigger recognition on noisy signals) the AND/OR conjunction of different trigger events is possible. As a unique feature it is possible to use deactivated channels as trigger sources.

## External trigger I/O

All instruments can be triggered using an external TTL signal. It's possible to use positive or negative edge also in combination with a programmable pulse width. An internally recognised trigger event can - when activated by software - be routed to the trigger connector to start external instruments.

## Pulse width

Defines the minimum or maximum width that a trigger pulse must have to generate a trigger event. Pulse width can be combined with channel trigger, pattern trigger and external trigger.

## Multiple Recording

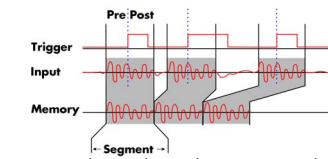

The Multiple Recording mode allows the recording of several trigger events with an extremely short re-arming time. The hardware doesn't need to be restarted in between. The on-board memory is divided in several segments of the same size. Each of them is filled with data if a trigger event occurs. Pre- and posttrigger of the segments can be programmed. The number of acquired segments is only limited by the used memory and is unlimited when using FIFO mode.

## Gated Sampling

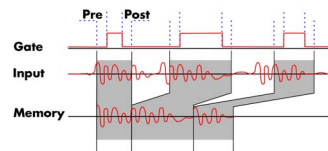

The Gated Sampling mode allows data recording controlled by an external gate signal. Data is only recorded if the gate signal has a programmed level. In addition a pre-area before start

of the gate signal as well as a post area after end of the gate signal can be acquired. The number of gate segments is only limited by the used memory and is unlimited when using FIFO mode.

## Timestamp

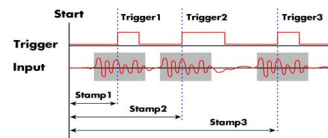

The timestamp function writes the time positions of the trigger events in an extra memory. The timestamps are relative to the start of recording, a defined zero time, externally synchronized to a radio clock, an IRIG-B or a GPS receiver.

Using the external synchronization gives a precise time relation for acquisitions of systems on different locations.

## ABA mode

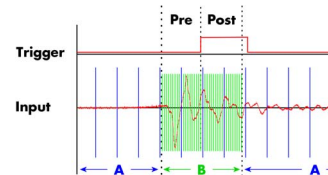

The ABA mode combines slow continuous data recording with fast acquisition on trigger events. The ABA mode works like a slow data logger combined with a fast digitizer. The exact

position of the trigger events is stored as timestamps in an extra memory.

## Option Embedded Server

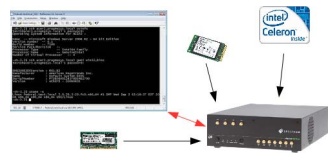

The option turns the digitizer-NETBOX/generatorNETBOX in a powerful PC that allows to run own programs on a small and remote data acquisition system. The digitizer-NETBOX/generatorNETBOX is en-

hanced by more memory, a powerful CPU, a freely accessible internal SSD and a remote software development access method.

The digitizer-NETBOX/generatorNETBOX can either run connected to LAN or it can run totally independent, storing data to the internal SSD. The original digitizer-NETBOX/generatorNETBOX remote instrument functionality is still 100% available. Running the embedded server option it is possible to pre-calculate results based on the acquired data, store acquisitions locally and to transfer just the required data or results parts in a client-server based software structure. A different example for the digitizer-NETBOX/generatorNETBOX embedded server is surveillance/logger appli-

cation which can run totally independent for days and send notification emails only over LAN or offloads stored data as soon as it's connected again.

Access to the embedded server is done through a standard text based Linux shell based on the ssh secure shell.

**External clock I/O**

Using a dedicated connector a sampling clock can be fed in from an external system. It's also possible to output the internally used sampling clock to synchronise external equipment to this clock.

**Reference clock**

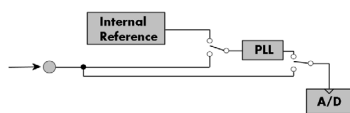

The option to use a precise external reference clock (typically 10 MHz) is necessary to synchronize the instrument for high-quality

measurements with external equipment (like a signal source). It's also possible to enhance the stability of the sampling clock in this way. The driver automatically generates the requested sampling clock from the fed in reference clock.

**DN2 / DN6 Technical Data**

**Analog Inputs**

Resolution		16 bit (±32000 values)
Input Range	software programmable	±50 mV, ±100 mV, ±250 mV, ±500 mV, ±1 V, ±2 V, ±5 V, ±10 V
Input Type	software programmable	Single-ended or True Differential (individually programmable per channel)
Input Offset (single-ended)	software programmable	programmable to ±5 V in steps of 1 mV, not exceeding ±10 V input
ADC Differential non linearity (DNL)	ADC only	465x: ±2 LSB, all others ±1 LSB
ADC Integral non linearity (INL)	ADC only	465x: ±2 LSB, all others ±1 LSB
Offset error (full speed)	after warm-up and calibration	≤ 0.1% of range ±0.2mV
Gain error (full speed)	after warm-up and calibration	≤ 0.1%
Crosstalk: 100 kHz Signal, 50 ohm termination	all input ranges	≤ -110 dB on adjacent channels
Analog Input impedance	fixed	1 MOhm    25 pF
Analog input coupling	fixed	DC
Over voltage protection (active card)	all ranges	±30 V
CMRR (Common Mode Rejection Ratio)	range ≤ ±500 mV	> 70 dB
CMRR (Common Mode Rejection Ratio)	range ≥ ±1V	> 46 dB
Channel selection (single-ended inputs)	software programmable	1, 2, 4, 8 or 16 channels (maximum is model dependent)
Channel selection (true differential inputs)	software programmable	1, 2, 4, 8 or 16 channels (maximum is model dependent)

**Trigger**

Available trigger modes	software programmable	Channel Trigger, External, Software, Window, Pulse, Re-Arm, Spike, Or/And, Delay
Trigger level resolution	software programmable	14 bit
Trigger edge	software programmable	Rising edge, falling edge or both edges
Trigger pulse width	software programmable	0 to [64k - 1] samples in steps of 1 sample
Trigger delay	software programmable	0 to [64k - 1] samples in steps of 1 sample
Multi, Gate: re-arming time		< 4 samples (+ programmed pretrigger)
Pretrigger at Multi, ABA, Gate, FIFO	software programmable	4 up to [8176 Samples / number of active channels] in steps of 4
Posttrigger	software programmable	4 up to [8G - 4] samples in steps of 4 (defining pretrigger in standard scope mode)
Memory depth	software programmable	8 up to [installed memory / number of active channels] samples in steps of 4
Multiple Recording/ABA segment size	software programmable	8 up to [installed memory / 2 / active channels] samples in steps of 4
Trigger output delay		One positive edge after internal trigger event
Internal/External trigger accuracy		1 sample
External trigger type (input and output)		3.3V LVTTTL compatible (5V tolerant)
External trigger input		Low ≤ 0.8 V, High ≥ 2.0 V, ≥ 8 ns in pulse stretch mode, ≥ 2 clock periods all other modes
External trigger maximum voltage		-0.5 V up to +5.7 V (internally clamped to 5.0V, 100 mA max. clamping current)

Trigger edge	software programmable	Rising edge, falling edge or both edges
Trigger impedance	software programmable	50 Ohm / high impedance (> 4kOhm)
External trigger output type		3.3 V LVTTTL
External trigger output levels		Low ≤ 0.4 V, High ≥ 2.4 V, TTL compatible
External trigger output drive strength		Capable of driving 50 ohm load, maximum drive strength ±128 mA

## **Clock**

Clock Modes	software programmable	internal PLL, internal quartz, external clock, external divided, external reference clock, sync
Internal clock range (PLL mode)	software programmable	1 kS/s to max using internal reference, 50kS/s to max using external reference clock
Internal clock accuracy		≤ 20 ppm
Internal clock setup granularity		≤ 1% of range (100M, 10M, 1M, 100k,...): Examples: range 1M to 10M: stepsize ≤ 100k
External reference clock range	software programmable	≥ 1.0 MHz and ≤ 125.0 MHz
External clock impedance	software programmable	50 Ohm / high impedance (> 4kOhm)
External clock range		see „Dynamic Parameters“ table below
External clock delay to internal clock		5.4 ns
External clock type/edge		3.3V LVTTTL compatible, rising edge used
External clock input		Low level ≤ 0.8 V, High level ≥ 2.0 V, duty cycle: 45% - 55%
External clock maximum voltage		-0.5 V up to +3.8 V (internally clamped to 3.3V, 100 mA max. clamping current)
External clock output type		3.3 V LVTTTL
External clock output levels		Low ≤ 0.4 V, High ≥ 2.4 V, TTL compatible
External clock output drive strength		Capable of driving 50 ohm load, maximum drive strength ±128 mA
Synchronization clock divider	software programmable	2 up to [8k - 2] in steps of 2
ABA mode clock divider for slow clock	software programmable	8 up to 524280 in steps of 8

## **Connectors**

Analog Inputs		9 mm BNC female (one for each single-ended input)	Cable-Type: Cab-9m-xx-xx
Trigger A Input/Output	programmable direction	9 mm BNC female	Cable-Type: Cab-9m-xx-xx
Trigger B Input		9 mm BNC female	Cable-Type: Cab-9m-xx-xx
Clock Input/Output	programmable direction	9 mm BNC female	Cable-Type: Cab-9m-xx-xx
Timestamp Reference Clock Input		9 mm BNC female	Cable-Type: Cab-9m-xx-xx

## **Option digitizerNETBOX/generatorNETBOX embedded server (DN2.xxx-Emb, DN6.xxx-Emb)**

CPU	Intel Quad Core 2 GHz
System memory	4 GByte RAM
System data storage	Internal 128 GByte SSD
Development access	Remote Linux command shell (ssh), no graphical interface (GUI) available
Accessible Hardware	Full access to Spectrum instruments, LAN, front panel LEDs, RAM, SSD
Integrated operating system	OpenSuse 12.2 with kernel 3.4.6.

## **Ethernet specific details**

LAN Connection	Standard RJ45 or Ethernet Buccaneer(R) for screw connection
LAN Speed	Auto Sensing: GBit Ethernet, 100BASE-T, 10BASE-T
Sustained Streaming speed	DN2.20, DN2.46, DN2.47, DN2.49, DN2.60 up to 70 MByte/s DN6.46, DN6.49 DN2.22, DN2.44, DN2.66 up to 100 MByte/s DN6.22, DN6.44, DN6.66
Used LAN Ports	Webserver: 80 mDNS Daemon: 5353 VISA Discovery Protocol: 111, 9757 UPNP Daemon: 1900 Spectrum Remote Server: 1026, 5025

## **Power connection details**

Mains AC power supply	Input voltage: 90 to 264 VAC, 50 to 60 Hz
AC power supply connector	IEC 60320-1-C14 (PC standard coupler)
Power supply cord	power cord included for Schuko contact (CEE 7/7)

## **Certification, Compliance, Warranty**

EMC Immunity	Compliant with CE Mark
EMC Emission	Compliant with CE Mark
Product warranty	5 years starting with the day of delivery
Software and firmware updates	Life-time, free of charge

## Dynamic Parameters

	M2i.4620	M2i.4621 M2i.4622 DN2.462	M2i.4630	M2i.4631 M2i.4632	M2i.4640	M2i.4641 M2i.4642 DN2.464	M2i.4650	M2i.4651 M2i.4652 DN2.465
max internal clock	200 kS/s		500 kS/s		1 MS/s		3 MS/s	
min external clock (special clock mode)	DC (DC)		DC (DC)		1 kS/s (DC)		1 kS/s (DC)	
max external clock (special clock mode)	200 kS/s (200 kS/s)		500 kS/s (500 kS/s)		1 MS/s (800 kS/s)		3 MS/s (2 MS/s)	
-3 dB bandwidth	>100 kHz		>250 kHz		>500 kHz		>1.5 MHz	
Zero noise level (Range $\geq \pm 500$ mV)	< 0.8 LSB rms		< 0.9 LSB rms		< 1.1 LSB rms		< 3.0 LSB rms	
Zero noise level (Range $< \pm 500$ mV)	< 8 $\mu$ V rms		< 10 $\mu$ V rms		< 17 $\mu$ V rms		< 30 $\mu$ V rms	
Test - sampling rate	200 kS/s		500 kS/s		1 MS/s		3 MS/s	
Test signal frequency	10 kHz		10 kHz		10 kHz		10 kHz	
SNR (typ)	91.8 dB	91.5 dB	91.2 dB	91.0 dB	91.0 dB	90.7 dB	84.0 dB	82.5 dB
THD (typ)	-102.0 dB	-101.7 dB	-101.8 dB	-101.6 dB	-101.5 dB	-100.8 dB	-94.5 dB	-90.1 dB
SFDR (typ), excl. harm.	112.0 dB	111.5 dB	112.0 dB	111.5 dB	112.0 dB	111.2 dB	107.0 dB	105.5 dB
ENOB (based on SNR)	15.0 bit	14.9 bit	14.9 bit	14.8 bit	14.8 bit	14.7 bit	13.6 bit	13.4 bit
ENOB (based on SINAD)	14.9 bit	14.8 bit	14.8 bit	14.7 bit	14.7 bit	14.6 bit	13.5 bit	13.3 bit

Dynamic parameters are measured at  $\pm 5$  V input range (if no other range is stated) and 1 MOhm termination with the sampling rate specified in the table. Measured parameters are averaged 20 times to get typical values. Test signal is a pure sine wave of the specified frequency with > 99% amplitude. SNR and RMS noise parameters may differ depending on the quality of the used PC. SNR = Signal to Noise Ratio, THD = Total Harmonic Distortion, SFDR = Spurious Free Dynamic Range, SINAD = Signal Noise and Distortion, ENOB = Effective Number of Bits. For a detailed description please see application note 002.

## DN6 specific Technical Data

### Environmental and Physical Details DN6.xxx

Dimension of Chassis without connectors or bumpers	L x W x H	464 mm x 431 mm x 131 mm
Dimension of Chassis with 19" rack mount option	L x W x H	464 mm x TBD mm x 131 mm (3U height)
Weight (3 internal acquisition/generation modules)		13.4 kgs, with rack mount kit: TBD kg
Weight (4 internal acquisition/generation modules)		12.9 kgs, with rack mount kit: TBD kg
Weight (5 internal acquisition/generation modules)		12.5 kgs, with rack mount kit: TBD kg
Weight (6 internal acquisition/generation modules)		12.1 kgs, with rack mount kit TBD kg
Warm up time		10 minutes
Operating temperature		0°C to 50°C
Storage temperature		-10°C to 70°C
Humidity		10% to 90%

### Power Consumption

	230 VAC	
16 channel versions, standard memory	TBD	TBD
24 channel versions, standard memory	TBD	TBD
32 channel versions, standard memory	TBD	TBD
40 channel versions, standard memory	TBD	TBD
48 channel versions, standard memory	TBD	TBD
16 channel versions, 2 x 1 GSample memory	TBD	TBD
24 channel versions, 3 x 1 GSample memory	TBD	TBD
32 channel versions, 4 x 1 GSample memory	TBD	TBD
40 channel versions, 5 x 1 GSample memory	TBD	TBD
48 channel versions, 6 x 1 GSample memory	TBD	TBD

### MTBF

MTBF	TBD hours
------	-----------

### Block diagram of digitizerNETBOX DN6

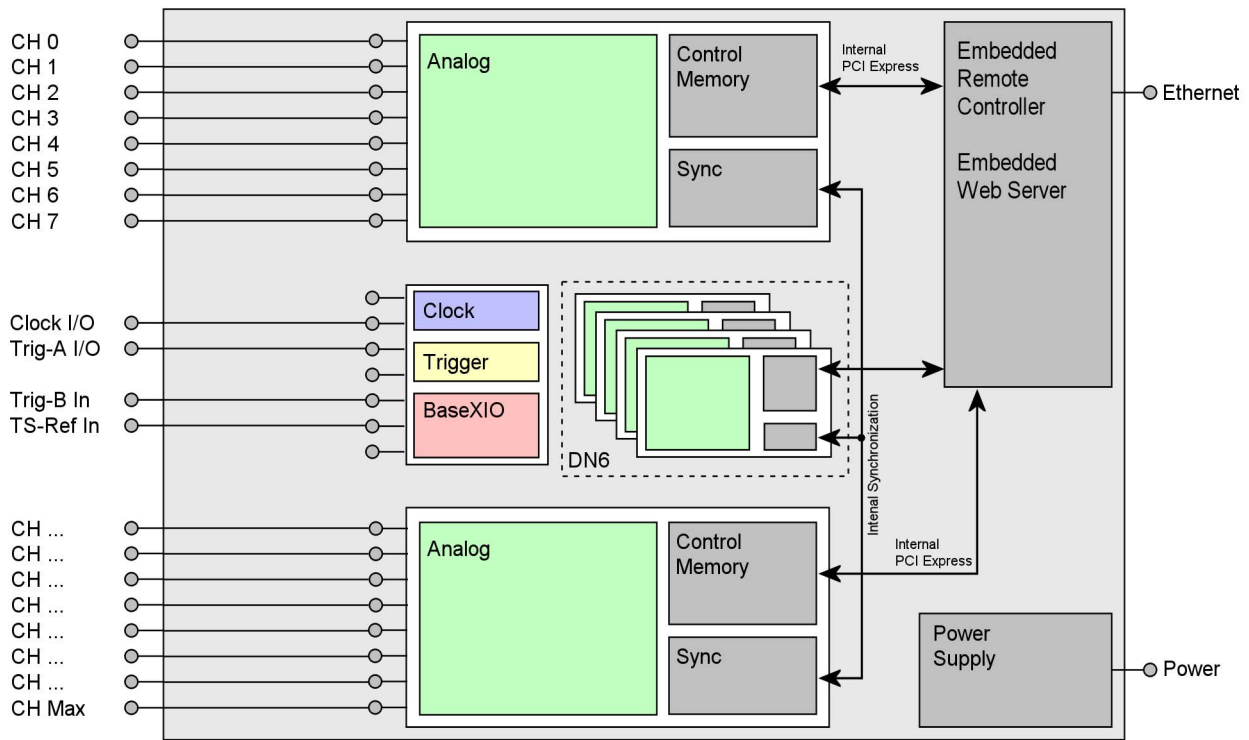

- The number of maximum channels and internal digitizer modules and existence of a synchronization Star-Hub is model dependent.

### Block diagram of digitizerNETBOX digitizer module DN6.46x

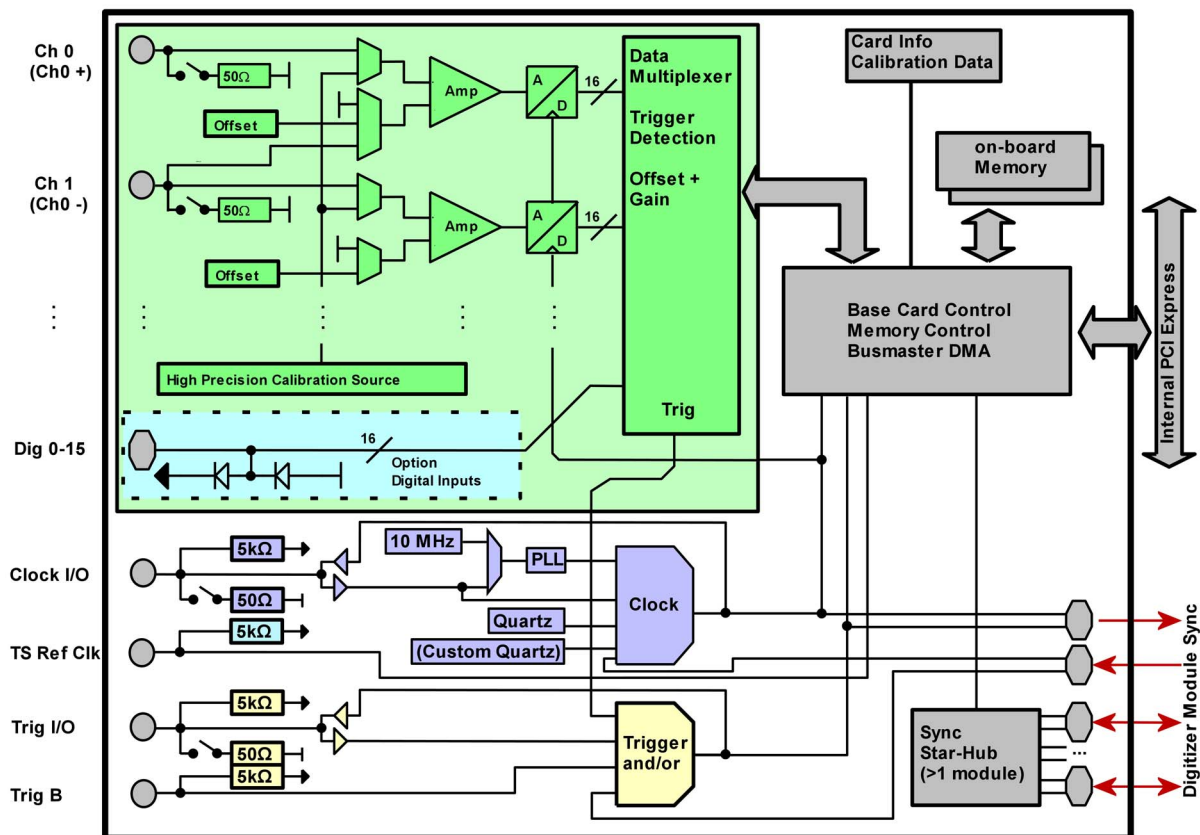



## Order Information

The digitizerNETBOX is equipped with a large internal memory for data storage and supports standard acquisition (Scope), FIFO acquisition (streaming), Multiple Recording, Gated Sampling, ABA mode and Timestamps. Operating system drivers for Windows/Linux 32 bit and 64 bit, drivers and examples for C/C++, IVI (Scope and Digitizer class), LabVIEW (Windows), MATLAB (Windows and Linux), LabWindows/CVI, .NET, Delphi, Visual Basic, Java, Python and a Professional license of the oscilloscope software SBench 6 are included.

The system is delivered with a connection cable meeting your countries power connection. Additional power connections with other standards are available as option.

## digitizerNETBOX DN6 - Ethernet/LXI Interface

Order no.	A/D Resolution	Single-Ended Channels	Differential Channels	Sampling Speed	Installed Memory	Available Memory Options
DN6.462-16	16 Bit	16 channels	16 channels	200 kS/s	2 x 512MS	2 x 1GS
DN6.462-24	16 Bit	24 channels	24 channels	200 kS/s	3 x 512MS	3 x 1GS
DN6.462-32	16 Bit	32 channels	-	200 kS/s	4 x 512MS	4 x 1GS
DN6.462-40	16 Bit	40 channels	-	200 kS/s	5 x 512MS	5 x 1GS
DN6.462-48	16 Bit	48channels	-	200 kS/s	6 x 512MS	6 x 1GS
DN6.464-16	16 Bit	16 channels	16 channels	1 MS/s	2 x 512MS	2 x 1GS
DN6.464-24	16 Bit	24 channels	24 channels	1 MS/s	3 x 512MS	3 x 1GS
DN6.464-32	16 Bit	32 channels	-	1 MS/s	4 x 512MS	4 x 1GS
DN6.464-40	16 Bit	40 channels	-	1 MS/s	5 x 512MS	5 x 1GS
DN6.464-48	16 Bit	48channels	-	1 MS/s	6 x 512MS	6 x 1GS
DN6.465-16	16 Bit	16 channels	16 channels	3 MS/s	2 x 512MS	2 x 1GS
DN6.465-24	16 Bit	24 channels	24 channels	3 MS/s	3 x 512MS	3 x 1GS
DN6.465-32	16 Bit	32 channels	-	3 MS/s	4 x 512MS	4 x 1GS
DN6.465-40	16 Bit	40 channels	-	3 MS/s	5 x 512MS	5 x 1GS
DN6.465-48	16 Bit	48channels	-	3 MS/s	6 x 512MS	6 x 1GS

## Options

Order no.	Option
DN6.xxx-Rack	19" rack mounting set for self mounting
DN6.xxx-Emb	Extension to Embedded Server: CPU, more memory, SSD. Access via remote Linux secure shell (ssh)
DN6.xxx-3x1GS	Memory extension to 3 x 1 GSample for xxx-24 versions
DN6.xxx-4x1GS	Memory extension to 4 x 1 GSample for xxx-32 versions
DN6.xxx-5x1GS	Memory extension to 5 x 1 GSample for xxx-40 versions
DN6.xxx-6x1GS	Memory extension to 6 x 1 GSample for xxx-48 versions
DN6.xxx-BTPWR	Boot on Power On: the digitizerNETBOX/generatorNETBOX automatically boots if power is switched on.

## Calibration

Order no.	Option
DN6.xxx-Recal	Recalibration of complete digitizerNETBOX/generatorNETBOX DN6 including calibration protocol

## BNC Cables

for Connections	Connection	Length	to SMA male	to SMA female	to BNC male	to SMB female
All	BNC male	80 cm	Cab-9m-3mA-80	Cab-9m-3fA-80	Cab-9m-9m-80	Cab-9m-3f-80
All	BNC male	200 cm	Cab-9m-3mA-200	Cab-9m-3fA-200	Cab-9m-9m-200	Cab-9m-3f-200

### Technical changes and printing errors possible

SBench, digitizerNETBOX and generatorNETBOX are registered trademarks of Spectrum Instrumentation GmbH. Microsoft, Visual C++, Visual Basic, Windows, Windows 98, Windows NT, Window 2000, Windows XP, Windows Vista, Windows 7, Windows 8 and Windows 10 are trademarks/registered trademarks of Microsoft Corporation. LabVIEW, DASyLab, Diadem and LabWindows/CVI are trademarks/registered trademarks of National Instruments Corporation. MATLAB is a trademark/registered trademark of The Mathworks, Inc. Keysight VEE, VEE Pro and VEE OneLab are trademarks/registered trademarks of Keysight Technologies, Inc. FlexPro is a registered trademark of Weisang GmbH & Co. KG. PCIe, PCI Express and PCI-X and PCI-SIG are trademarks of PCI-SIG. LXI is a registered trademark of the LXI Consortium. PICMG and CompactPCI are trademarks of the PCI Industrial Computer Manufacturers Group. Oracle and Java are registered trademarks of Oracle and/or its affiliates. Intel and Intel Xeon are trademarks or registered trademarks of Intel Corporation. AMD and Opteron are trademarks or registered trademarks of Advanced Micro Devices.